

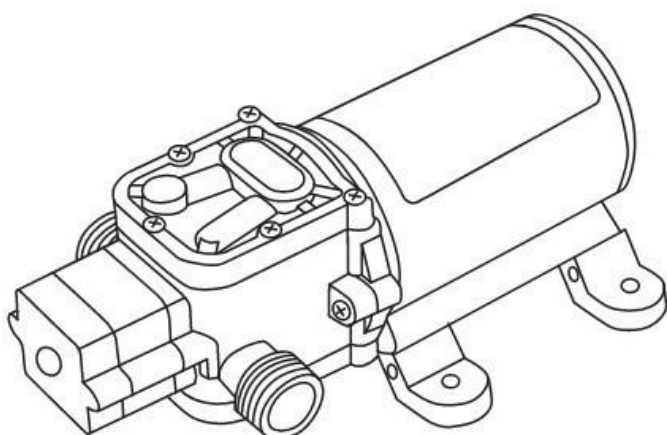

## INSTRUCTION MANUAL

### PWP-06 HEAVY-DUTY 12VDC WATER PUMP

#### FLEXIMAKE PWP-06 12VDC WATER PUMP



#### SPECIFICATIONS

**Motor:** ■ Permanent magnet ■ Ball bearings on front and rear end-bell ■ Soft noise absorbing mounts ■ Corrosion-resistant materials ■ Thermal overload protection

**Pump:** ■ Diaphragm positive displacement design ■ Pump able to run dry without damage for extended periods ■ Self-prime up to 2m with suction lift ■ Runs quietly ■ Suitable for potable water applications ■ Pressure Cut-Off switch for automatic ON/OFF based on the demand

Voltage	12V DC
Maximum Current	6.0 Amps
Open Flow Rate	6.0 litres/min
Maximum Pressure	60PSI
Max Water Temperature	60°C
Self-Priming Distance	2m (Suction Lift)
Dimensions(Approx.) mm	178L x 100W x 79H
Weight (Approx.)	1.2kg

**Inlet and Discharge Ports:** ■ 13mm (1/2") Threaded Straight

#### PRECAUTIONS!

**⚠ Explosive Environments:** Do not operate the pump in an explosive environment. Avoid using the pump to transfer flammable liquids. The occurrence of arcing from motor bushes or pressure cut-off switches could potentially lead to explosions.

**⚠ Design and Usage:** This pump is designed specifically for water pumping applications. The pump can handle a maximum water temperature of 60°C. Refrain from using the pump for chemicals, as this can lead to pump damage and potential hazards.

**⚠ Duty Cycle and Operating Conditions:** The pump's duty cycle is influenced by ambient temperature, flow, and pressure. Equipped with thermal protection, the pump features a built-in thermal breaker. In the event of the pump overheating, the thermal breaker will operate, halting the motor. Once the pump cools down, the breaker will automatically reset, allowing pumping to resume. It's important to note that the pump will recommence operations without prior warning.

**⚠ Pump Installation Location:** The pump motor's surface can become hot during operation. To prevent hazards, avoid situating the pump motor near combustible materials and low-temperature plastics.

#### MOUNTING GUIDELINES

□ **Location and Ventilation:** Choose a dry area for mounting the pump, ensuring adequate ventilation. In case the pump needs to be placed within an enclosed space, it is essential to establish provisions for proper ventilation or implement a suitable cooling method.

□ **Self-Priming Capability:** This pump features a self-priming capability, allowing it to initiate operation without manual priming. Typically, it can self-prime up to two meters. However, it is important to note that this priming distance might vary based on the specific pump configuration.

□ **Mounting Orientation:** The pump can be securely mounted in any orientation. If choosing a vertical placement, ensure that the pump head is positioned vertically downwards. This precaution reduces the risk of water entering the motor in an unlikely event of a leak. When mounting vertically, first attach the motor mounts, then the mounts at the pump head end, whilst supporting the weight of the pump.

□ **Securing Pump Feet:** Slide the rubber feet completely into the four mounting tracks if they were not already installed upon receiving the pump. Utilize appropriate hardware to firmly secure the pump feet in place. These feet are designed to provide vibration isolation, contributing to a stable and smooth pump operation. While fastening the hardware, exercise caution not to excessively compress the foot, as this could adversely impact its performance.

## PLUMBING GUIDELINES

□ **Hose Selection:** Opt for flexible high-pressure hoses (i.e. braided or reinforced) that are compatible with the type of water to be pumped. For instance, if dealing with potable water applications, employ hoses designed for potable water use.

□ **Secure Hose Arrangement:** Arrange the hoses in a manner that avoids exerting unnecessary stress on the pump fittings.

□ **Optimal Routing:** When installing hoses, prioritize the use of the shortest possible route to ensure efficient water flow.

□ **Inlet and Discharge Ports:** The pump is designed with 13mm (1/2") threaded straight ports for both the inlet and discharge connections. Before connecting the pump to your plumbing system, ensure that you remove the shipping plugs from these ports. It is normal for a small amount of water from factory testing to spill out during this process.

To achieve a leakproof connection, we recommend using thread seal tapes.

✂️ **Note:** An arrow marked on the pump head indicates the direction of flow and helps identify the inlet and discharge ports.

## WIRING GUIDELINES

□ **Plug-in Power Supply:** When opting for a plug-in power supply, you can use a cigarette lighter plug and cable that has an appropriate current carrying capacity. Ensure that the cigarette lighter socket circuit is equipped with a fuse. If uncertain, it is advisable to select a cigarette lighter plug and cable with a built-in fuse. To facilitate convenient control of the pump's power ON/OFF, consider one that contains a built-in switch.

□ **Fixed Wired Power Supply:** When setting up a fixed wiring system, utilize an automotive electrical cable with a current carrying capacity suitable for accommodating the maximum amps required by the pump. Seek guidance from your automotive electrical cable supplier or consult an auto electrician for advice on cable selection and sizing. Install a suitably rated on-off switch on the positive Red(+) motor lead. Incorporate properly rated fuse protection within the positive wire Red(+) to ensure safety.

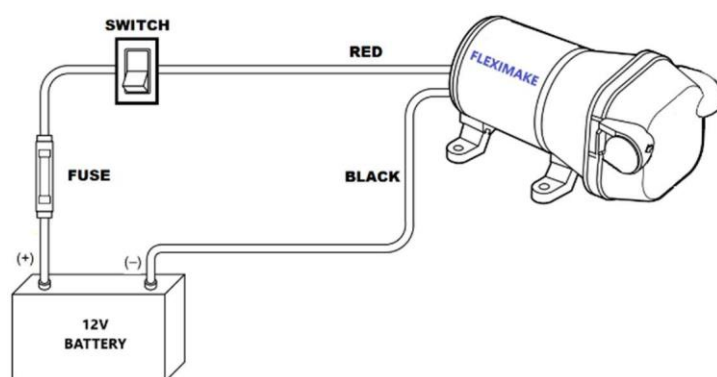

Circuit Diagram for Fixed Wiring Installation.

## GUIDELINES FOR PORTABLE APPLICATIONS

For portable applications, we recommend attaching the pump to a base, such as a plywood board. Mount a toggle switch and a fuse onto the board as well as the use of cables with the necessary length, equipped with alligator clips, to connect the pump to a battery for the best portable application. Alternatively, it is possible to use an appropriately rated cigarette lighter plug for power supply.

### □ PRESSURE CUT-OFF SWITCH

The pressure cut-off switch operates when the discharge side pressure exceeds the set limit and interrupts the power to the pump motor. For the PWP-06 pump, the cut-off switch pressure is pre-set to 60 psi. This configuration ensures that the pump automatically halts its operation when the outlet water circuit is closed, such as when a tap or valve is shut. Upon opening the outlet water circuit, the pressure at the pump outlet decreases, prompting the pump to start automatically and initiate the water pumping process.

**⚠ WARNING:** Improper adjustment to the pressure switch setting can result in severe overload and premature failure of the pump. In situations where plumbing is restricted or the flow rate is intentionally reduced to a very low rate using a valve or tap, the outlet pressure can build up more rapidly than water is being released. This can lead to the pressure cut-off switch cycling rapidly between ON and OFF states. Frequent and rapid ON/OFF cycling may ultimately lead to damage to the pump.

## TROUBLESHOOTING

**⚠ WARNING: BEFORE SERVICING PUMP, TURN OFF PUMP AND DRAIN WATER FROM SYSTEM!**

### Failure to Prime - Motor operates, but no pump discharge ?

- ☞ Restricted intake or discharge line, clogged strainer
- ☞ Air sucking through the intake piping or vacuum leak in the intake piping
- ☞ Debris in the pump, swollen/dry valves
- ☞ Punctured pump diaphragm

- ☞ Crack in pump housing or lose assembly screws

### Motor fails to turn on ?

- ☞ Blown fuse in the electrical circuit
- ☞ The motor is hot and the internal thermal protection is activated. This protection will reset once motor is cool
- ☞ Pump circuit has no power
- ☞ Loose wiring connection
- ☞ Defective motor
- ☞ Long cable run with too thin cables (i.e. not receiving sufficient voltage due to voltage drops in the cables)
- ☞ Seized pump diaphragm
- ☞ Water Frozen in the pump

**⚠ WARNING:** Allowing water to freeze within the system can result in significant damage to the pump. To prevent such issues, it is essential to thoroughly drain the pump and remove it from the system before freezing conditions occur. This precautionary measure offers the best assurance against potential damages.

### Low Flow and Pressure ?

- ☞ Air leak at the pump intake
- ☞ Accumulation of debris inside pump and plumbing
- ☞ Worn pump bearing (excessive noise)
- ☞ Punctured pump diaphragm
- ☞ Defective motor

### Pulsating Flow ?

- ☞ Restricted pump discharge piping
- ☞ Clogged or undersized discharge lines, fittings, and valves

### Leaks from Pump Head or Switch ?

- ☞ Loose screws at switch or pump head
- ☞ Switch diaphragm ruptured or pinched
- ☞ Punctured diaphragm if water is present in the drive assembly.

### The pump will not shut off when the Faucet or tap is closed?

- ☞ Leaky plumbing on discharge
- ☞ Leaky valve (for example leaky toilets)
- ☞ Air trapped in discharge side plumbing (for example water heater) or pump head

- ☞ The voltage at the pump is not within the normal range (12V +/-10%)
  - ☞ Loose drive assembly or pump head screws
  - ☞ Valves held open by debris or swollen rubber.
  - ☞ Shut off pressure setting is too high; Loosen the adjustment screw carefully and gradually
- ⚠ WARNING:** Improper adjustment to the pressure switch setting may cause severe overload and premature failure of the pump

- Noisy or Rough Operation?**
- ☞ Vibrating loose plumbing
  - ☞ Pump plumbed with rigid pipe cause noise to transmit
  - ☞ The mounting surface amplifies the noise  
Loose or over-compressed mounting feet of the pump
  - ☞ Trapped air in the system; Bleed the air from the system and make the system airtight

**MAIN PARTS**

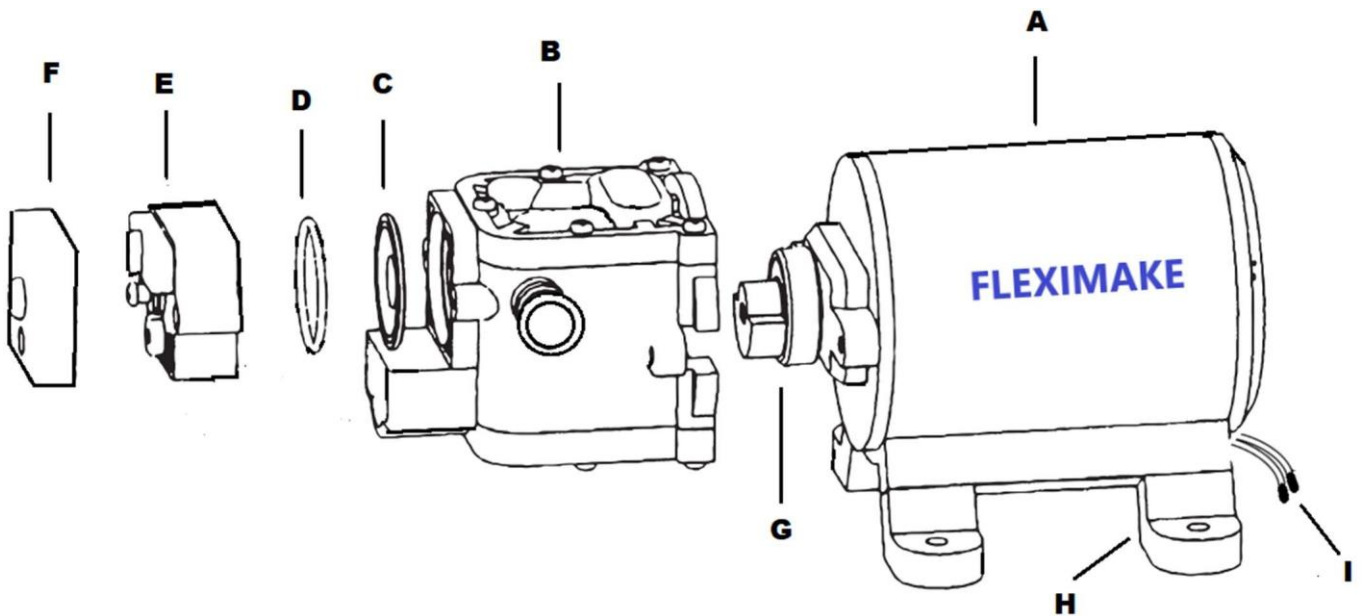

<b>A</b> Motor	<b>D</b> O-ring	<b>G</b> Eccentric Drive Wheel
<b>B</b> Pump Head	<b>E</b> Pressure Cut-off Switch	<b>H</b> Mounting Feet
<b>C</b> Pressure Gasket	<b>F</b> Cover for Pressure Switch	<b>I</b> 12V dc Wires (+)Red, (-)Black

☞ **Note:** The above parts drawing is provided as a generalized guide for reference purposes. Please note that actual parts may vary in appearance from the diagram.

 <p><b>Fleximake Pty Ltd</b></p>	<p>Web: <a href="http://fleximake.com.au">fleximake.com.au</a>                  Online Store: <a href="http://fmestore.com.au">fmestore.com.au</a>                  Email: <a href="mailto:sales@fleximake.com.au">sales@fleximake.com.au</a></p>
<p><b>VIC</b>                  33 Tatterson Road                  Dandenong South, VIC 3175                  Tel: 1300 195 295   03 8772 2228</p>	<p><b>NSW</b>                  2/36 Holbeche Rd                  Arndell Park, NSW 2148                  Tel: 1300 195 295   02 8610 2228</p>